

①	C1020
②	SUS304
③	CARTRIDGE HEATER

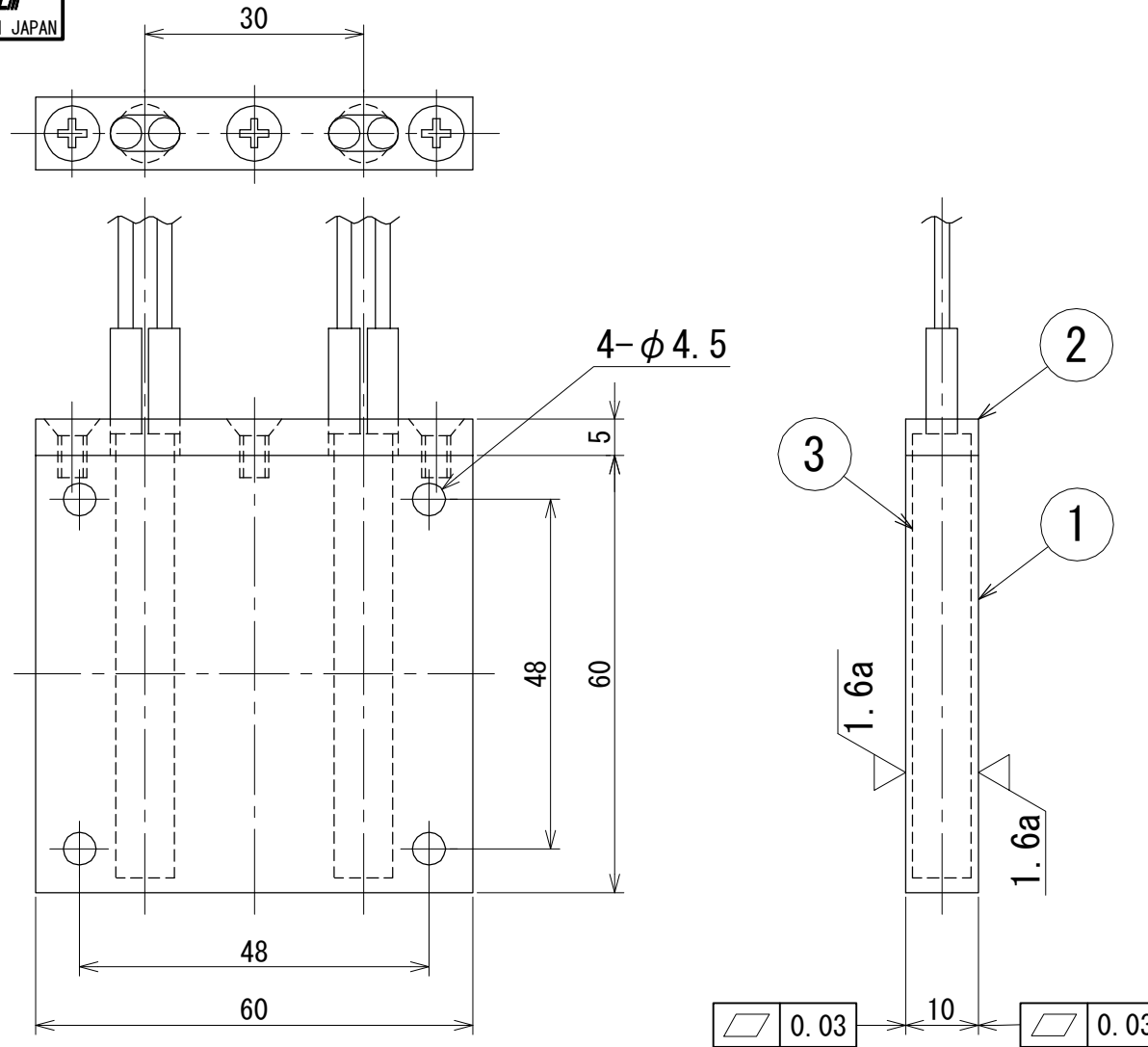

POWER : 400 [W] (200W × 2)
 VOLTAGE : 110 [V]
 MAXIMUM SURFACE TEMPERATURE : 600 [°C]MAX
 WEIGHT : ABOUT 325 [g]
 SCALE : NOT TO SCALE (NTS)
 UNIT : mm
 PROJECTION : THIRD ANGLE PROJECTION METHOD
 DIMENSIONAL TOLERANCE : ±0.5

1. Performance data on drawings, catalogs, handling manuals, and our documentation is reference only, and is not guaranteed.
2. This product is designed by us. Production and copy of this product without our permission is not permitted.

TITLE	HOT PLATE
USE FOR	TEST EQUIPMENT, MANUFACTURING EQUIPMENT, OTHERS
ITEM NUMBER	HU-400C